

PRODUCT INSTRUCTIONS

ORBI-JET™ X22 (PN 63230)

PI-077



Simple, self-rotating nozzle capable of accepting four compound-angle, replaceable tips. The four compound-angle jets provide a wider cleaning pattern for reduced streaking and an option to clean three separate ways. Operating pressures up to 22,500 psi (1550 bar).

Read these instructions thoroughly before installing, connecting, or using the ORBI-JET X22. If any questions remain, call JETSTREAM at (800) 231-8192 or (832) 590-1300. Also read the yellow JETSTREAM SAFETY WARNING pamphlet included with the shipment of your new ORBI-JET X22 nozzle and reproduced inside this publication. This product is sold with the understanding that the purchaser agrees to thoroughly train all operators and maintenance personnel in the correct and safe installation, operation and maintenance of the product and to provide adequate supervision of personnel at all times. Retain these instructions for future reference. If this product is resold or otherwise conveyed, purchaser must pass on the instructions to the new user.

Table of Contents

Section 1: Safety	3
Section 2: Product Description	14
Section 3: Preparation for Use	15
Section 4: Setup	16
Section 5: Operation	18
Section 6: Service	20
Section 7: Troubleshooting	24
Appendix A	
Exploded View	25
Parts Placement.....	26
Appendix B	
Accessories	27
Nozzle Extensions.....	27
Magnets	27
OX Series - Carbide Nozzles.....	27
UHPX/ UHPXi Series - Sapphire Nozzles	27
Flow Charts	28
Warranty.....	32

Section 1: Safety

This section includes all the same information included in the yellow JETSTREAM SAFETY WARNING pamphlet.



This information was prepared to aid in the identification of potentially unsafe conditions when using high pressure waterblast equipment. It should be noted that other potential hazards may exist which might have not been mentioned in this brochure.

In all cases, JETSTREAM products are sold with the understanding that the purchaser agrees to thoroughly train all operating and maintenance personnel in the correct and safe installation, operation of maintenance of waterblast equipment and to provide adequate supervision of personnel at all times.

Read the following in its entirety before connecting, operating or repairing equipment. Purchasers and operators also should be familiar with the current version of the “Industry Best Practices for the Use of High Pressure Waterjetting Equipment” published by the Waterjet Technology Association, as well as any applicable OSHA regulations, standards and guidelines.

Should any questions arise concerning safe and proper procedure, contact JETSTREAM prior to the installation or use at (800) 231-8192 or (832) 590-1300.

GENERAL WATERBLAST

1. Use only clear, clean water in high pressure system.
2. Place barricades with warning signs or barricade tape around work area.
3. Outfit all operators with Personal Protective Equipment (PPE). Hard hat with plastic face shield, rainsuit, non-skid knee boots **with metatarsal protection**, gloves, ear protection and body armor rated for operating pressures are considered minimum safety equipment. Proper respiratory protection is required where dangerous fumes or dust is present or created by the waterblasting operation. Follow applicable OSHA regulations, standards and guidelines regarding the use of respiratory protection if harmful fumes or dust is present during, or created by the waterblasting operation
4. Use products intended for high pressure waterblasting only.
5. **No product should be altered** without written consent of the manufacturer.
6. **Read and follow all manufacturer's instructions** prior to using any waterblast product. Contact manufacturer.
7. Thoroughly review alternative methods before initiating any potentially dangerous waterblasting operation. Fully automated, semi-automated, and/or mechanized methods should all be considered first. Contact the applicable waterblasting manufacturers for assistance and recommendations.
8. The operator handling the cleaning device (with nozzle) must always have control of water pressure. A surface cleaning operator should operate a trigger style control gun capable of instantaneously stopping pressure to nozzle. A tube cleaning lance operator should operate a foot gun capable of instantaneously stopping pressure to the lance.
9. Inspect the condition of all components prior to use. Use no items which are in questionable condition.
10. Check the condition of thread connections prior to the make-up of any high pressure connection. Use Teflon tape and anti-seize on male pipe (NPT) thread for sealing purposes. Do not let tape overlap the male pipe thread end. Tape fragments may enter system water stream and clog nozzle's orifices.

Do Not use a component with missing or damaged threads on the high pressure connections.

11. Properly tighten all high pressure connections. All NPT connections must have a minimum engagement of four (4) threads. Pipe (NPT) connections should be made up hand tight plus two (2) full wrenched turns. **Do not** tighten NPT threads past two (2) wrenched turns.

⚠ CAUTION Use wrench flats (when available) or a properly adjusted smooth jaw plier wrench (JS PN 64119) for tightening components. Avoid using pipe wrench as wrench marks will cause high pressure components to crack and fail.

12. All high pressure hose connections require a hose restraint (whip check), including connection at fluid end discharge.

13. Before attaching a nozzle to the control gun or tube cleaning lance, **operate the pump at low speed to purge** dirt and debris from system. **Dirt and debris can clog nozzle orifice(s) and cause excessive system pressure which could lead to a lance failure.**

14. With nozzle installed, **operate the pump at a low speed (low pressure) for test.** Should system repairs or adjustments be necessary, stop pump and relieve all pressure before making required repairs or adjustments. The pump operator should watch the nozzle operator at all times in case any difficulty arises and it becomes necessary to depressurize system. If the pump operator does not have a clear line of sight to the nozzle operator, it may be necessary to have another employee available to communicate between the nozzle and pump operators.

15. With the system operating properly, **increase pump speed slowly until operating pressure is reached** and adjusted. Pressure adjustments should always be made slowly. The nozzle operator shall be warned before any pressure adjustment is made by the pump operator. A sudden change in reaction force may cause the nozzle operator to lose balance.

16. Use **minimum pressure required** for cleaning. Do not exceed the operating pressure of the system's lowest pressure-rated component. All equipment pressure rating markers and warning tags should be left intact.

17. Waterblast operators must be made aware that the **cleaning nozzle's discharge jets(s) can inflict serious body wounds.** Supervisors should demonstrate the potential danger of discharge jet(s) by showing all new operators the effect of a waterjet by cutting a scrap piece of wood such as a 2" x 4".

18. If equipment malfunctions or a system malfunction is suspected, immediately stop cleaning activity and relieve the pressure in the system before attempting any repairs. Always follow the manufacturer's repair instructions.
19. Only trained persons should be authorized to perform any maintenance or repair.
20. Following any repairs, the system should be operated at low pressure for test. Bring equipment up to operating pressure slowly.
21. For shutdown in freezing conditions, even for brief periods, drain water from all components. Prior to starting operations in freezing conditions, the operation of all equipment components must be checked carefully to make sure components are not frozen and can be operated.
22. Store components properly by protecting them from damage when not in use. Be sure all safety warning tags and markers remain intact.

CONTROL GUNS AND DEVICES

1. **Read General Safety** section before connecting or using control guns or control devices.
2. Thoroughly review alternative methods before initiating any potentially dangerous shotgunning or hand lancing operation. Fully automated, semi-automated, and/or mechanized methods should all be considered first. Contact the applicable waterblasting manufacturers for assistance and recommendations.

⚠ WARNING As described in the Industry Best Practices for the Use of High Pressure Waterblasting Equipment published by the Waterjet Technology Association, the standard shotgun barrel length shall be a minimum length of 48" to minimize the risk of nozzle discharge accidentally striking the operator's feet, legs, or body. See Section 11.10.6. The WJTA has recognized that deviations or variances from these best practices may be acceptable under certain circumstances. See Section 2.7. If users believe deviation from this 48" standard is acceptable, they should follow procedures outlined in Section 2.7 to minimize risk to the operator. Among other things, users should ensure that other measures to perform the work have been considered and exhausted, senior safety management and customers have considered and approved the deviation, operators have been properly trained and warned about any increased risk associated with the deviation, and operators are wearing all appropriate PPE, including body armor rated for

the operating pressure.

3. Prior to use, thoroughly check control gun or control device for smooth and proper operation. Control guns and control devices should also be checked for proper operation before each operating shift. Do not use any control gun or control device that has not been checked before your operating shift.
4. A control gun operator using a hand-held gun should position and brace his body for the gun's rearward reaction force before depressing gun trigger. Gun's rearward reaction should be a maximum force of 40 to 50 lbs. (or 1/3 body weight of operator.) The control gun operator should maintain firm, solid footing to counter gun's rearward reaction.
5. The use of a Safety Shroud and a Safety Whip Hose with handheld control guns is strongly recommended for additional operator protection against a burst occurring in the high pressure hose connected to the gun. Use of Hand Grip and Shoulder Stock in hand-held control guns will provide greater operator comfort and safety.
6. Fall protection should be provided when blasting on scaffolding or sloping surface per OSHA guidelines. Do not operate a hand-held gun while standing on slippery surfaces.
7. The control gun operator should always start blasting with a low system pressure and slowly increase blasting pressure. Depress and release control gun trigger/pedal several times at operating pressure to check the control gun's operation before starting cleaning operations.
8. A dump type control gun should always open fully and reduce the system pressure to near zero immediately when its trigger/pedal is released. If this type of control gun does not relieve system pressure immediately or system pressure does not fall below 200 psi when trigger/pedal is released, do not use the control gun.
9. The control gun operator should never pass a control gun to another operator without first stopping the pump and water flow to the control gun. Passing off a control gun without first stopping system waterflow is dangerous because of possible accidental trigger actuation.
10. Do not use a control gun or control device that has malfunctioned or you suspect malfunctioned without having it repaired and/or thoroughly checked for proper operation by a qualified high pressure maintenance mechanic or your supervisor.
11. Do not use a control gun that does not have a trigger guard.
12. Never tie, wedge or clamp a control gun's trigger in the closed position.

13. All electric throttle control cords should be rated for wet conditions. All cord connections and switches should be kept out of water.
14. Any hose used for transporting dump water back to pump should have a large enough diameter and short enough length so that potentially dangerous back pressure is kept low. Protect hose from traffic.
15. Hand-operated control guns should never be used as foot-operated devices.

PRESSURE RELIEF DEVICES

1. **Read General Safety** section prior to installing Relief Valve and/or Pressure Relief Devices.
2. A waterblast system should include both primary and secondary pressure relief protection:
 - A. For primary protection a primary rupture disc assembly or spring-loaded relief set at 1.2 times, maximum operating pressure is recommended (i.e. relief valve is set at 12,000 psi if maximum operating pressure is 10,000 psi)
 - B. For secondary protection a rupture disc assembly containing a manufacturer's approved disc having a burst rating of 1.4 times maximum operating pressure is recommended.

⚠ WARNING Only use a rupture disc holder which will NOT permit the use of coins or other objects in place of discs.

3. Relief devices should never be mounted so the discharge could strike personnel.
4. Never install a shut-off valve between the pump and relief device.
5. "Set pressure" must be prominently displayed on all relief devices. Never install or use a relief device unless its "set pressure" is known.
6. Do not attempt to correct a leaking relief valve by increasing spring tension as this will increase its set pressure.
7. Do not use a pressure relief valve as a combination relief and throttling device.
8. Keep relief valve dry during freezing conditions.

NOTE: Pressure relief devices are imperative for the protection of both operator and equipment from dangerous over-pressurization.

HIGH PRESSURE HOSE

1. **Read General Safety** section prior to connecting high pressure hose.
2. Do not use a high pressure hose with a burst rating less than 2.5 times the pressure at which it will operate. 10,000 psi operating pressure high pressure must have a minimum 25,000 psi burst rating. 8,000 psi operating hose must have a minimum 22,500 psi burst rating.
3. Do not use a high pressure hose that has an unknown burst rating or manufacturer's operating pressure rating.
4. Use of a Safety Shroud is strongly recommended for added safety where hose connects to control gun.
5. Use of hose restraint (whip check) is required at all hose connections, including connections at fluid end.
6. Always apply wrench to wrench flats when making threaded connections. Do not apply wrench on the end fitting ferrule (collar).
7. Remove hose from service if:
 - A. Cover is damaged and reinforcing wires are exposed to rust and corrosion;
 - B. Cover is loose, has blisters or bulges;
 - C. Hose has been crushed or kinked;
 - D. End fitting shows evidence of damage, slippage, or leakage.
 - E. Hose has been exposed to pressures greater than 50% of burst rating; or
 - F. Hose is three or more years old, regardless of condition.
8. Disconnect, drain, coil and store hose properly after use.
9. Never attempt to repair or recouple high pressure hoses in field. High pressure hose end fittings are the permanently crimped type and can only be properly installed with hydraulic crimping equipment.

NOZZLES

1. **Read General Safety** section. Read the appropriate Safety Warning (i.e. Flexible Tube Cleaning Lances or Rigid Tube Cleaning Lances) prior to installing nozzle on lance.
2. Nozzle flow ratings must be compatible with pump discharge and pump pressure rating. A flow rating is stamped on the side of JETSTREAM'S nozzles. (See Nozzle Flow Rating Chart in JETSTREAM Catalog.)
3. Use only nozzles with a manufacturer's pressure rating of at least the operating pressure or a burst rating or no less than 3.0 times the desired operating pressure.

4. Prior to installation, make sure the nozzle has no clogged orifices.
5. **For 15,000 psi models** - Apply 3 - 4 wraps of Teflon tape to male connection thread on the barrel. Apply anti-seize compound over the sealant tape for additional protection against galling in connection threads. Wrench connection 1 1/2 - 2 turns past hand tight. A minimal thread engagement of four (4) threads should exist on all Jetstream NPT pipe connections.

For 22,500 psi models - Apply anti-gall compound to the gland threads and male cone on control gun front barrel. DO NOT use Teflon tape. Check blast nozzle size before installing the nozzle. Make sure the nozzle orifices are not too small in order to prevent excessive system pressure when the gun's control valve trigger/pedal is depressed.

6. **▲ CAUTION** Use wrench flats (when available) or a properly adjusted smooth jaw plier wrench (JS PN 64119) to tighten nozzle. Avoid using pipe wrench as wrench marks will cause nozzles to crack and fail.

7. Special nozzles requiring a thread locking pin must have the pin installed prior to use or the nozzle may unscrew from the lance while in service and cause the lance to blow back toward the operator.

8. With nozzles requiring adjustment, always read applicable instructions.

9. Blocked orifice(s) can cause excessive system pressure and failure. If orifice(s) appear clogged or partially blocked with dirt or debris, remove nozzle from control gun or lance and clean immediately.

10. **Remove nozzle from service if:**

- A. Nozzle is split or damaged;
- B. Nozzle sidewall is worn by more than 25% at any point;
- C. Nozzle's ability to hold pressure is questionable
- D. Threads are missing or damaged

FLEXIBLE TUBE CLEANING LANCES

1. **Read General Safety** section and Nozzle Safety Warnings prior to connecting flex lances.

2. **Do not** use a flex lance with a burst rating less than 2.25 times the pressure at which it will operate. 10,000 psi operating pressure flex lances **must** have a **minimum** 22,500 psi burst rating. 8,000 psi operating pressure flex lances **must** have a **minimum** 18,000 psi burst rating.

3. **Do not** use a flex lance that has an unknown burst or unknown manufacturer's operating pressure rating.

4. **Never use a lance which is kinked, worn, frayed** or whose abilities to hold pressure is questionable.

5. **Do not** use a lance which has damaged or missing threads.
6. **Clearance** between lance and tube deposits **must be sufficient** to allow unrestricted backflow of water and debris. With tubes containing hard deposits this clearance should be 1/8" **minimum** on the diameter (or 1/16" per side) of the lance. With tubes containing soft, pliable deposits this clearance should be greater. **Insufficient side clearance may cause lance to blow back toward operator.**
7. **▲ WARNING** Serious injury may occur should a lance with live nozzle exit tube. Use anti-withdrawal device to prevent lance from exiting tube unexpectedly.
8. The following **JETSTREAM** lance accessories are **strongly recommended** for safer lance operation:
 - A. **Lance Strain Relief** - Helps prevent lance inlet end fitting failure.
 - B. **Lance Stinger** - Affords the operator greater control of nozzle. Establishes a "safety zone" so operator knows when nozzle is about to exit tube; will eliminate possibility of nozzle and lance "double back" toward operator within large diameter pipe.
 - C. **Anti-withdrawal device** prevents the lance from exiting the tube or pipe. Contact JETSTREAM for additional information regarding these products.
9. **Use only nozzles designed for use with flex lances** (i.e. nozzle drilled with sufficient rearward orifices so nozzle pulls lance through tube.)
10. If lance end fittings do not have wrench flats, use properly adjusted smooth jaw plier wrench (JS PN 64119) to connect lance to pressure source and nozzle onto lance. Apply wrench on lance and fitting **directly behind end fitting thread (not on fitting ferrule or collar)** when installing nozzle on lance. Do not clamp on the lance hose itself with vise when installing nozzle.
11. Avoid rough handling, stretching or straining of lance.
12. Never attempt to "ramrod" flex lance through blockages or to repair or recouple lances.
13. After use, drain, coil and store lance properly. Be sure safety tags remain intact.

RIGID TUBE CLEANING LANCES

1. **Read General Safety** section and Nozzle Safety Warnings prior to connecting rigid lances.
2. Do not use a rigid lance with a burst rating less than 3.0 times the

pressure at which it will operate. 10,000 psi operating pressure rigid lances must have a minimum 30,000 psi burst rating. Do not use a rigid lance that has an unknown burst or unknown manufacturer's operating pressure rating.

3. Clearance between lance and tube must be sufficient to permit the unrestricted backflow of water and debris. With tubes containing hard deposits this clearance should be 1/8" minimum on the diameter (or 1/16" per side) of the lance. With tubes containing soft, pliable deposits this clearance should be greater. Insufficient side clearance may cause lance to blow back toward operator.

4. Be sure nozzle, lance and adapter thread sizes are compatible before installing nozzle and adapter on lance. Do not use a rigid lance that has damaged or missing threads.

5. Use wrench flats (when available) or a properly adjusted smooth jaw plier wrench (JS PN 64119) to connect lance. Do not use pipe wrench as wrench marks will cause high pressure components to crack and fail.

6. A rigid lance over 4 ft long requires two men for support and safe operation. Operator at tube should use a foot control gun so he can instantly relieve system pressure in case of emergency.

7. When using and moving lance, support it in a manner to avoid stress and possible breakage at inlet end connection.

8. Never "ramrod" lance into tube blockage.

9. Transport and store lances in tubes or racks to avoid bending, corrosion or other damage. Damaged lances (bends, mars) should be removed from service.

HIGH PRESSURE FITTINGS

1. **Read General Safety** section prior to installing fittings in system.

2. Use non-brass or non-cast iron fittings which are made for high pressure waterblast use.

3. Use only high pressure fittings which are clearly marked with the operating pressure.

4. High pressure fittings should have a known burst rating of not less than 3.0 times system operating pressure. Never use a damaged or corroded fitting or one with damaged or missing threads.

5. Use only high pressure rated fittings and hose in the waterblast system. For 10,000 psi waterblast service all fittings and hose should have a minimum burst rating of 25,000 psi; for 15,000 psi service they should have a minimum burst rating of 37,500 psi; for 20,000 psi service

they should have a minimum burst rating of 50,000 psi.

6. Use wrench flats (when available) or a properly adjusted smooth jaw plier wrench (JS PN 64119) to tighten fittings. Avoid using pipe wrench as wrench marks will cause high pressure fittings to crack and fail.

REPLACEMENT PARTS

1. **Read General Safety** section prior to repairing equipment and installing replacement parts.

2. Only trained persons should be authorized to perform maintenance or repairs to equipment.

3. Read and follow all manufacturer's repair instructions. All tool, torque, clearance and lubrication recommendations should be followed.

4. During replacement of any part, inspect mating part for wear and replace if necessary.

5. Do not attempt to install or use a part whose dimensions, clearances, function or use are suspect.

6. Test repaired equipment carefully and thoroughly before putting it into service. Do not put any piece of repaired equipment into service if its performance is questionable. If repaired equipment performance is questionable, call manufacturer of repair parts for assistance.

This section concludes all the same information included in the yellow JETSTREAM SAFETY WARNING pamphlet (PI-082).

Section 2: Product Description

The Orbi-Jet X22™ surface cleaning nozzle is a self-powered rotating nozzle that uses two or four straight-pattern, hard-hitting tungsten carbide or sapphire nozzles. These nozzles rotate at a controlled speed while producing concentrated streams to give you more cleaning production than a fan tip.

The Orbi-Jet X22 has an eddy current magnetic braking system which controls rotational speed for maximum cleaning and minimum wear.

The Orbi-Jet X22 is designed to be completely rebuilt in the field in less than five minutes. It comes standard with a lightweight shroud which protects the rotor from abrasion to help protect your investment.

The Orbi-Jet X22 is rated up to 22,500 psi. The maximum working pressure is stamped at the bottom of the Orbi-Jet X22.

Product Specifications

Model Name	Orbi-Jet X22 (PN 63230)
Maximum Operating Pressure (psi)	22,500
Minimum Operating Pressure (psi)	5000
Maximum Flow (gpm)	18
Maximum Operating Pressure (bar)	1550
Minimum Operating Pressure (bar)	344
Maximum Flow (l/min)	68.1
Inlet Connection	9/16"MP Female
Speed Range (RPM)	1000-1500
Nozzle Types Accepted	OX, UHPX, UHPXi
Diameter (in)	2
Length (in)	3.7
Weight (lbs)	2.1
Diameter (mm)	51
Length (mm)	94
Weight (kg)	.95

Section 3: Preparation for Use

3.0 BEFORE PUTTING ORBI-JET X22 INTO SERVICE

NEW ORBI-JET X22

3.1 Check the Orbi-Jet X22 carefully upon removal from its shipping container for damage.

3.2 A new Orbi-Jet X22 is shipped assembled with exception of the nozzles. The tool is ready to use upon installation of nozzles per instructions in Section 4: Setup.

3.3 Review nozzle charts in the Appendix to determine proper flow rates for each application.

PREVIOUSLY USED ORBI-JET X22

Before Installing the Orbi-Jet X22 onto control gun:

3.3 Inspect all components. The Orbi-Jet X22 rotating nozzle head should turn by hand with minimal resistance.

3.4 The Orbi-Jet X22 nozzle should be inspected and cleaned to insure no debris has entered the orifice that could plug the nozzle and over-pressurize the system.

3.5 Remove the Orbi-Jet X22 from service if the body or rotor show signs of cracking or excessive abrasion.

Section 4: Setup

4.0 CONNECTING ORBI-JET X22

The Orbi-Jet X22 must be used with a minimum control gun barrel length of 48 inches to prevent nozzle discharge from accidentally striking the Operator's feet, legs or body.

4.1 Prior to installing the Orbi-Jet X22 onto the control gun barrel, engage the pump and depress the control gun trigger to clear any debris from the system. Check tightness of the retaining screw on the end of the Orbi-Jet X22 by using an allen wrench on the retaining screw while backing up the mandrel with another allen wrench.

For 22,500 psi operation (9/16" MP FML Inlet)

1. Apply anti-seize compound to the gland threads and cone on the control gun front barrel. Do not use Teflon tape.
2. Install the Orbi-Jet X22 onto the front barrel and tighten to 50 lbs. ft.

For 15,000 psi operation (NPT FML Inlet)

Use a female NPT to male 9/16" MP adapter for 15,000 psi operation.

1. Apply 3-4 wraps of Teflon thread sealant tape to the male connection thread on the control gun barrel.
2. Apply anti-seize compound over the sealant tape for protection against galling in connection threads.
3. Tighten the connection 1-1/2 to 2 turns past hand tight. All NPT pipe connections should have a minimum thread engagement of (4) threads.
4. Apply anti-seize compound to the gland threads and cone on the male end of the adapter.

NOTE: Do not use Teflon tape.

5. Install the Orbi-Jet X22 onto the adapter and tighten to 50 lbs. ft.

4.2 NOZZLE INSTALLATION

Check the blast nozzle size before installing the nozzles into the Orbi-Jet X22. Make sure the nozzle orifices are not too small in order to prevent excessive system pressure when the gun's control valve trigger/pedal is depressed. Refer to the charts in Appendix B for the proper flow rate and thrust for your application.

NOTE: Three spray pattern options are available using the different combinations of nozzles and plugs. Two narrow ports can be plugged for a wider spray pattern, two wide ports plugged for a more narrow and harder

hitting spray pattern, or all ports nozzled for complete coverage.

1. Remove Twis-Lok shroud to access Orbi-Jet X22 rotor. Shroud can be removed by rotating counter-clockwise relative to Orbi-Jet X22 body (if nozzles are facing you). If Orbi-Jet is already installed on control gun, shroud can be slid down barrel while installing nozzles.
2. New Orbi-Jet X22 comes with nozzle plugs installed. Determine spray pattern to be used and remove plugs (if needed) using a 3/16" hex key.
3. If plugs are to be used, apply anti-seize compound to male threads and cone on nozzle plugs and install into correct ports using 3/16" hex key. Be sure the plug retainer does not loosen from the retaining screw.
4. Apply anti-seize compound to male threads of nozzles (and cone if using UHPX nozzles) and install using adjustable or 5/16" wrench. Hand tighten to 50 lbs. in.
5. Replace Twis-Lok shroud by sliding over body, making sure the protrusions on body and cutouts in shroud line up. Secure by rotating shroud clockwise relative to Orbi-Jet X22 body.

▲ WARNING A Multi-Gun Valve (MGV) must be used when two or more dump gun operators are connected to a single waterblast unit. Each gun operator must have independent control of nozzle pressure at their location.

Section 5: Operation

5.0 OPERATING ORBI-JET X22

As per the WJTA-IMCA Recommended Practices, all operators shall follow the OSHA regulations for personal protective equipment. (OSHA guidelines for Personal Protective Equipment are available in document number 3151-12R 2004, which can be obtained from www.osha.gov.) All operators shall be issued suitable head protection, eye protection, hearing protection, body protection, hand and foot protection and respiratory protection (if needed). For detailed specifications on all protections required, refer to the WJTA-IMCA 'Recommended Practices for the Use of High Pressure Waterjetting Equipment' Section 6, Protective Equipment For Personnel.

▲ IMPORTANT Water cleanliness is very important. A filter no larger than 10 microns should be used on the water supply inlet.

5.1 Use only thoroughly trained operators to perform cleaning operations with the Orbi-Jet X22.

5.2 Do not connect multiple dump type control guns together to a single high pressure water source without the use of a Multi-Gun Valve (MGV) to make each gun operator independent of the other operators. Call Jetstream for assistance if two or more dump type control guns must be used in the waterblast system.

5.3 The gun operator must be made aware that the Orbi-Jet X22 nozzle's discharge jet(s) can inflict serious body wounds.

5.4 Carefully inspect the gun for damage or missing parts. Make sure that all components work smoothly and freely.

5.5 Place barricades with warning signs or barricade tape around work area. This includes the waterblast unit and all high pressure hoses.

5.6 The gun operator must be outfitted with safety apparel. The minimum: hard hat with plastic face shield, rainsuit, steel toe non-skid boots, shin and foot guards and non-slip gloves.

5.7 Before starting to blast, check for correct barrel length (48"). Get into blasting position with the gun. Move the gun around to make sure the blast nozzle cannot cross any part of the legs, feet or body. Check gun for smooth and proper operation. DO NOT use the gun or Orbi-Jet X22 if it has not been cleaned and inspected before the start of the working shift.

5.8 Protect the control gun in freezing conditions. Stop using the gun if any low temperature operational problems occur. Drain the gun and remove its cartridge if it is not in use in freezing conditions.

5.9 During operation, it is normal for water to leak out the front of the rotor from around the set screw. This leak-by water comes from the water bearing that the tool operates on (see Figure A).



Figure A

NOTE: Orbi-Jet X22 shown with only one nozzle installed. This is for visual purposes only and the tool should never be run this way.

Section 6: Service

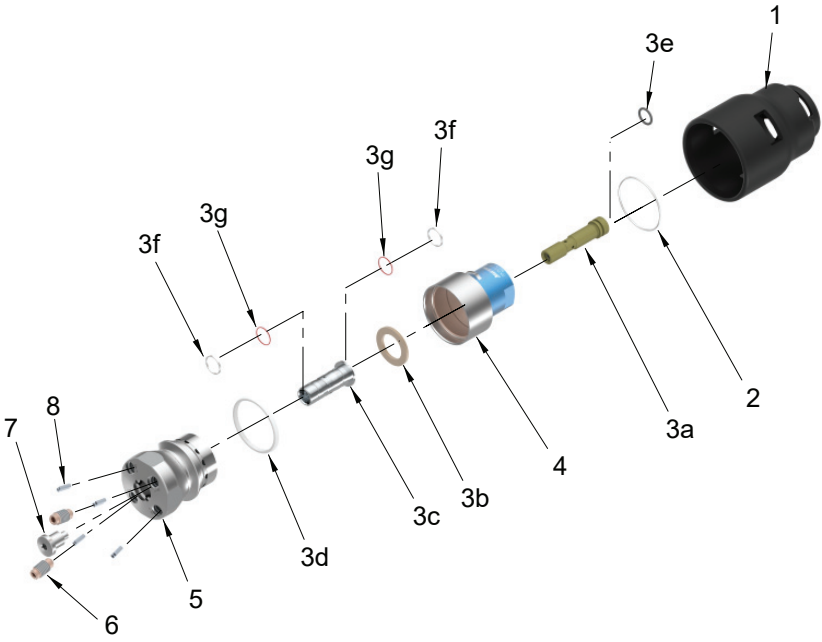

Figure B

Assembly PN 63230			
Item	Qty	Part Number	Description
1	1	63202	Twis-Lok Shroud
2	1	63304	Shroud O-Ring
3a-3g	1	52305	Rebuild Kit
3a	1	52352	Mandrel
3b	1	52351	Thrust Washer
3c	1	52349	Bushing
3d	1	52159	Rotor Seal
3e	1	26053	O-ring, Mandrel
3f	2	52683	Backup Ring, Bushing
3g	2	26760	O-ring, Bushing
4	1	63207	Body
5	1	54277	Rotor
6	2	UHPXi-PLUG	Plug, UHPXi
7	2	54276	Retaining Screw
8	4	28435	Straightening Vane
9	1	63302	Maintenance Kit*

NOTE: Part numbers and descriptions are subject to change without notice.
 *Maintenance Kit includes items 2, 3e, 3f, & 3g

6.0 ORBI-JET X22 MAINTENANCE

When not in use the Orbi-Jet X22 should be removed from the control gun, washed off (to remove any deposits that could impede rotation), and coated with a spray-type non-silicone based lubricant.

See YouTube for videos showing Orbi-Jet X22 service.



Jetstream Service



6.1 DISASSEMBLY

1. Remove the Orbi-Jet X22 from the control gun using open-ended or adjustable wrench on both barrel connection and Orbi-Jet X22 body and turning counter-clockwise.
2. Remove Twis-Lok shroud (1) by rotating shroud counter-clockwise relative to body (4) (if nozzles are facing you).
3. Remove the retaining screw (8). It may be necessary to secure the mandrel (3a) with a hex key to prevent it from turning when breaking the retaining screw (8) loose.
4. Slide the rotor (5) off the mandrel (3a) and then remove the mandrel from the body (4).
5. If a new mandrel o-ring (3e) is needed, carefully remove the old o-ring (3e) using a hook pick.
6. Remove the thrust washer (3b).
7. With your hands, hold the rotor (5) in one hand and use the mandrel (3a) to push the bushing (3c) out of the rotor (5) as shown in Figure C.
8. If new bushing o-rings (3f, 3g) are needed, carefully remove the old o-rings (3f, 3g) using a hook pick.
9. Remove rotor seal (3d) and shroud o-ring (2) if they need replacement.
10. Remove nozzles if they need to be replaced.
11. Clean and inspect all parts being reused.

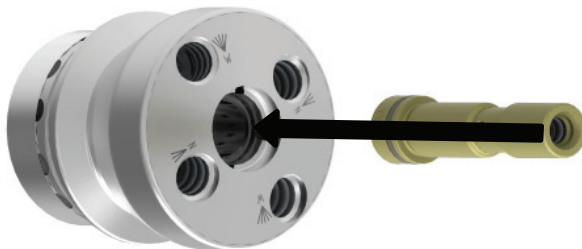

Figure C

6.2 ASSEMBLY & REBUILD KIT INSTALLATION

1. Ensure the new mandrel (3a), new flange bushing (3c), and the rotor (5) are clean.
2. Slide a new rotor seal (3d) over the magnets on the rotor (5). Work it up over the barb, and into the groove. Lip should face magnets after installation. See Figure D for proper orientation when installed.



Figure D

3. Apply light coat of o-ring lube to o-rings to reduce friction and ease installation. Install new o-rings (3f, 3g) onto the flange bushing (3c). See Figure E for proper orientation of o-rings when installed.
NOTE: O-ring (3g) color subject to change.



Figure E

4. Wet o-rings (3f, 3g) on the flange bushing (3c) very lightly with water or grease. Slide the flange bushing (3c) into the rotor (5). The head of the flange bushing (3c) should now be flush up against the back of the rotor (5) with no gap between them.
5. Place the thrust washer (3b) over the flange bushing (3c) on the bottom surface of the rotor (5).
6. Install the new o-ring (3e) onto the mandrel (3a).
7. Insert the mandrel (3a) into the body (4) with a rotating motion to ease the installation of the o-ring (3e).

8. Install the rotor (5) into the mandrel (3a)/body (4). To ensure thrust washer stays in proper location, it is best to install with nozzle ports facing downward and sliding mandrel (3a) /body into rotor (5).
9. Tighten the retaining screw (8) into the end of the rotor (5) to about 50 lbs. in. using a hex key while holding the mandrel (3a) in place with another hex key. The retaining screw (8) should be flush with the contours on the face of the rotor (5). If it is recessed, check to make sure the flange bushing (3c) and the mandrel (3a) are each fully installed, and the thrust washer (3b) is in its proper location.
10. Screw the nozzles into the ports on the face of the rotor (5). The high pressure connection system used on these nozzles does not require that they be tightened heavily and will not improve streaking if this is done. Instead, they should be torqued lightly to about 50 lbs. in. to ensure that they will not loosen during operation. If the nozzles are installed properly and not overtightened, the pressure connection will last almost indefinitely.
11. If the shroud o-ring (2) has become loose or needs replacement, place into the groove on the back face of the body (4). See Figure F for proper installation of shroud o-ring.



Figure F

12. Slide the Twis-Lok shroud (1) over the body (4), making sure the protrusions on the radial surface of the inlet end of the body fit into the cutouts on the shroud. Secure by holding the body (4) and rotating the shroud (1) clockwise (if nozzles are facing you) to lock into place.
13. Install the Orbi-Jet X22 onto the control gun.

Section 7: Troubleshooting

7.0 ORBI-JET X22 TROUBLESHOOTING

Problem	Possible Cause	Remedy
Will not spin	Nozzles worn or wrong size	Replace nozzles
	Kit worn	Replace kit
	Thrust washer moved	Reinstall correctly; may need replacement
	Debris	Clean*
Spins slowly	Incorrect nozzle size or worn nozzles	Replace nozzles
	Debris	Clean*
Pressure too low	Nozzle worn or wrong size	Replace nozzles
	Kit worn	Replace kit
	Connections not tight, leak	Correct
Excessive flow or pump will no longer come up to pressure	Nozzle worn or wrong size	Replace nozzles
	Kit worn	Replace kit
	Worn parts**	Replace parts

* To clean the Orbi-Jet X22 follow 6.1 DISASSEMBLY. If the mandrel and bushing surfaces are free from high spots and major scratches during inspection and cleaning, and the problem is not resolved, the parts must be replaced. Reassemble according to 6.2 ASSEMBLY.

**Remove the retaining screw (8) and test the fit on the flange bushing (3c) on the mandrel (3a). There should be almost no visible gap between them. Inspect the inside of the flange bushing (3c) for lines, scratches, or steps which would indicate excessive wear. If these examinations reveal excessive wear, the parts must be replaced.

Appendix A

Exploded View

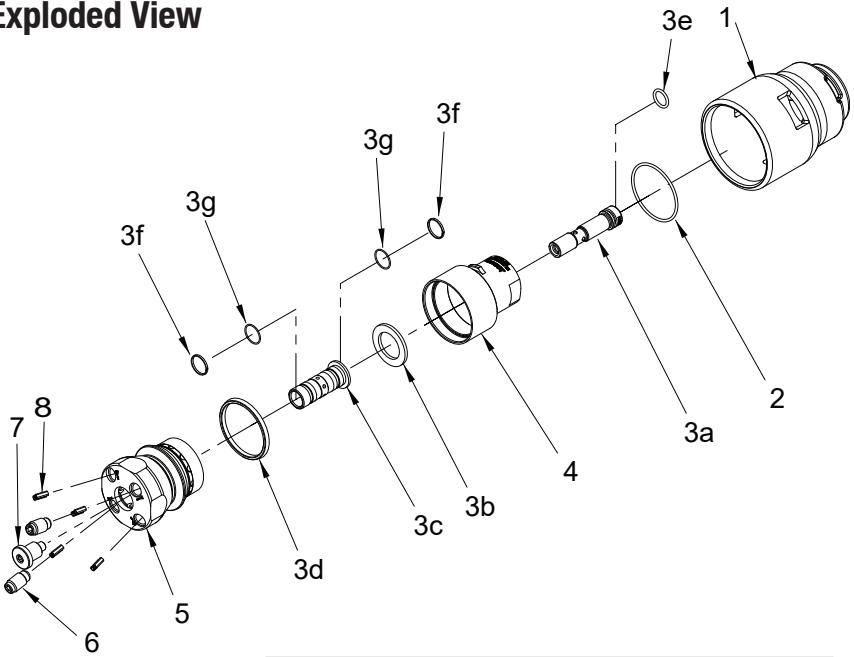

Figure G

Assembly PN 63230			
Item	Qty	Part Number	Description
1	1	63202	Twis-Lok Shroud
2	1	63304	Shroud O-Ring
3a-3g	1	52305	Rebuild Kit
3a	1	52352	Mandrel
3b	1	52351	Thrust Washer
3c	1	52349	Bushing
3d	1	52159	Rotor Seal
3e	1	26053	O-ring, Mandrel
3f	2	52683	Backup Ring, Bushing
3g	2	26760	O-ring, Bushing
4	1	63207	Body
5	1	54277	Rotor
6	2	UHPXi-PLUG	Plug, UHPXi
7	2	54276	Retaining Screw
8	4	28435	Straightening Vane
9	1	63302	Maintenance Kit*

NOTE: Part numbers and descriptions are subject to change without notice.

*Maintenance Kit includes items 2, 3e, 3f, & 3g

Parts Placement

Orbi-Jet X22 available in hard case kit form:

- PN 63305 Premium Kit
- PN 63306 15K Kit
- PN 63392 Starter Kit

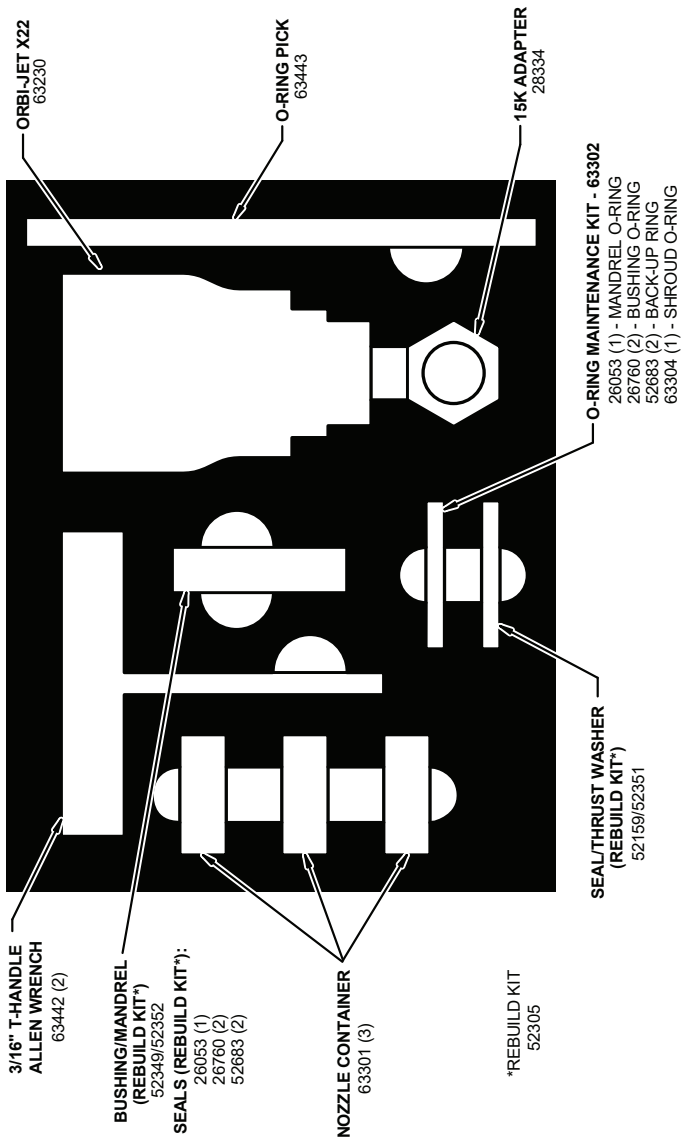

Figure H

Appendix B

Accessories

Nozzle Extensions



- Extensions are installed into the Orbi-Jet X22 nozzle to provide a wider cleaning pattern and serve as flow straighteners, further reducing turbulence for more aggressive waterjets. Sold individually.
- Part number 53844

Magnets

- Part number 26758N & 26758S

OX Series - Carbide Nozzles

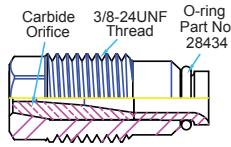

- High-productivity carbide nozzles designed for the Orbi-Jet X22.
- Specifically engineered carbide orifices provide the most aggressive waterjets available.
- Efficient design reduces turbulence and orifice wear.
- Select nozzles from the following charts by choosing operating pressure, desired flow, and two or four-nozzle operation.

UHPX/ UHPXi Series - Sapphire Nozzles

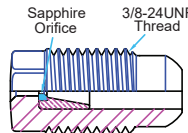
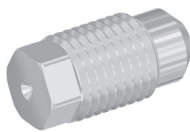

- High-productivity sapphire nozzles designed for the Orbi-Jet X22.
- Tapered orifice retainer reduces turbulence and provides a cohesive, aggressive waterjet.
- Sapphire orifices are more durable than carbide.
- UHPX have a 5/16" external hex and UHPXi have a 5/32" internal hex.
Note: UHPXi nozzles are not flush.
- Plug PN UHPXi-PLUG

Flow Charts

TWO OX NOZZLES

OX NOZZLE PART NO.	ORIFICE DIAMETER		5,000 psi (345 bar)		7,500 psi (517 bar)		10,000 psi (690 bar)		12,500 psi (862 bar)		15,000 psi (1,034 bar)		17,500 psi (1,207 bar)		20,000 psi (1,379 bar)		22,500 psi (1,551 bar)	
	in	mm	gpm	lpm	gpm	lpm	gpm	lpm	gpm	lpm	gpm	lpm	gpm	lpm	gpm	lpm	gpm	lpm
OX-018	0.018	0.46	1.9	7.2	2.5	9.5	3.0	11.4	3.4	12.9	3.6	13.6	3.7	14.0	3.9	14.8	4.0	15.1
OX-025	0.025	0.64	3.1	11.7	3.9	14.8	4.6	17.4	5.3	20.1	5.6	21.2	6.0	22.7	6.3	23.8	6.5	24.6
OX-029	0.029	0.74	4.0	15.1	5.0	18.9	5.8	22.0	6.6	25.0	7.1	26.9	7.6	28.8	8.0	30.3	8.4	31.8
OX-033	0.033	0.84	4.9	18.5	6.2	23.5	7.2	27.3	8.2	31.0	8.8	33.3	9.4	35.6	9.9	37.5	10.4	39.4
OX-038	0.038	0.97	6.3	23.8	7.9	29.9	9.2	34.8	10.4	39.4	11.3	42.8	12.0	45.4	12.7	48.1	13.4	50.7
OX-042	0.042	1.07	7.6	28.8	9.4	35.6	11.0	41.6	12.4	46.9	13.4	50.7	14.4	54.5	15.3	57.9	16.1	60.9
OX-046	0.046	1.17	9.0	34.1	11.1	42.0	13.0	49.2	14.6	55.3	15.9	60.2	17.0	64.3	18.1	68.5	19.1	72.3
OX-055	0.055	1.40	12.6	47.7	15.6	59.0	18.1	68.5	20.3	76.8	22.1	83.6	23.8	90.1	25.3	95.8	26.7	101.1
OX-063	0.063	1.60	16.3	61.7	20.1	76.1	23.4	88.6	26.2	99.2	28.6	108.3	30.7	116.2	32.7	123.8	34.6	131.0
OX-067	0.067	1.70	18.4	69.6	22.7	85.9	26.3	99.5	29.4	111.3	32.1	121.5	34.6	131.0	36.9	139.7	39.0	147.6
OX-070	0.070	1.78	20.0	75.7	24.7	93.5	28.6	108.3	32.0	121.1	35.0	132.5	37.6	142.3	40.1	151.8	42.5	160.9



Thrust numbers are marginal for rotation speed and may not clean well in difficult applications. Thrust < 25 lb-F

Manual Blasting 25 lb-F < Thrust < 67 lb-F

Light Duty Automated Blasting 67 lb-F < Thrust < 150 lb-F

Heavy Duty Automated Blasting Thrust > 150 lb-F

FOUR OX NOZZLES																		
OX NOZZLE PART NO.	ORIFICE DIAMETER		5,000 psi (345 bar)		7,500 psi (517 bar)		10,000 psi (690 bar)		12,500 psi (862 bar)		15,000 psi (1,034 bar)		17,500 psi (1,207 bar)		20,000 psi (1,379 bar)		22,500 psi (1,551 bar)	
	in	mm	gpm	lpm	gpm	lpm	gpm	lpm	gpm	lpm	gpm	lpm	gpm	lpm	gpm	lpm	gpm	lpm
OX-018	0.018	0.46	3.2	12.1	4.0	15.1	4.8	18.2	5.4	20.4	5.8	22.0	6.1	23.1	6.4	24.2	6.7	25.4
OX-025	0.025	0.64	5.6	21.2	6.9	26.1	8.1	30.7	9.2	34.8	9.9	37.5	10.6	40.1	11.2	42.4	11.8	44.7
OX-029	0.029	0.74	7.3	27.6	9.0	34.1	10.6	40.1	11.9	45.0	12.9	48.8	13.8	52.2	14.6	55.3	15.4	58.3
OX-033	0.033	0.84	9.2	34.8	11.4	43.1	13.3	50.3	15.0	56.8	16.3	61.7	17.5	66.2	18.6	70.4	19.6	74.2
OX-038	0.038	0.97	12.1	45.8	14.9	56.4	17.3	65.5	19.4	73.4	21.2	80.2	22.7	85.9	24.2	91.6	25.5	96.5
OX-042	0.042	1.07	14.6	55.3	18.0	68.1	20.9	79.1	23.4	88.6	25.5	96.5	27.5	104.1	29.3	110.9	30.9	117.0
OX-046	0.046	1.17	17.4	65.9	21.4	81.0	24.8	93.9	27.8	105.2	30.4	115.1	32.7	123.8	34.8	131.7	36.8	139.3
OX-055	0.055	1.40	24.6	93.1	30.2	114.3	35.0	132.5	39.2	148.4	42.8	162.0	46.1	174.5	49.2	186.2	52.1	197.2
OX-063	0.063	1.60	32.1	121.5	39.4	149.1	45.6	172.6	51.0	193.0	55.8	211.2	60.1	227.5	64.2	243.0	68.0	257.4
OX-067	0.067	1.70	36.2	137.0	44.4	168.1	51.4	194.5	57.6	218.0	62.9	238.1	67.8	256.6	72.4	274.0	76.7	290.3
OX-070	0.070	1.78	39.4	149.1	48.4	183.2	56.0	212.0	62.7	237.3	68.6	259.7	73.9	279.7	78.9	298.6	83.6	316.4

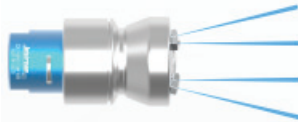

Thrust numbers are marginal for rotation speed and may not clean well in difficult applications. Thrust < 25 lb-F

Manual Blasting 25 lb-F < Thrust < 67 lb-F

Light Duty Automated Blasting 67 lb-F < Thrust < 150 lb-F

Heavy Duty Automated Blasting Thrust > 150 lb-F

UHPX NOZZLE		ORIFICE DIAMETER		5,000 psi (345 bar)		7,500 psi (517 bar)		10,000 psi (690 bar)		12,500 psi (862 bar)		15,000 psi (1,034 bar)		17,500 psi (1,207 bar)		20,000 psi (1,379 bar)		22,500 psi (1,551 bar)	
UHPX PART NO.	UHPX NOZZLE PART NO.	mm		gpm	lpm	gpm	lpm	gpm	lpm	gpm	lpm	gpm	lpm	gpm	lpm	gpm	lpm	gpm	lpm
		in	mm																
UHPX-018	UHPXI-018	0.018	0.46	1.5	5.7	2.0	7.6	2.4	9.1	2.8	10.6	2.9	11.0	3.0	11.4	3.1	11.7	3.2	12.1
UHPX-019	UHPXI-019	0.019	0.48	1.6	6.1	2.1	7.9	2.6	9.8	3.0	11.4	3.1	11.7	3.2	12.1	3.4	12.9	3.5	13.2
UHPX-020	UHPXI-020	0.020	0.51	1.8	6.8	2.3	8.7	2.7	10.2	3.1	11.7	3.3	12.5	3.4	12.9	3.6	13.6	3.7	14.0
UHPX-021	UHPXI-021	0.021	0.53	1.9	7.2	2.4	9.1	2.9	11.0	3.3	12.5	3.5	13.2	3.7	14.0	3.8	14.4	3.9	14.8
UHPX-022	UHPXI-022	0.022	0.56	2.0	7.6	2.6	9.8	3.1	11.7	3.5	13.2	3.7	14.0	3.9	14.8	4.0	15.1	4.2	15.9
UHPX-023	UHPXI-023	0.023	0.58	2.1	7.9	2.7	10.2	3.3	12.5	3.7	14.0	3.9	14.8	4.1	15.5	4.3	16.3	4.5	17.0
UHPX-024	UHPXI-024	0.024	0.61	2.3	8.7	2.9	11.0	3.4	12.9	3.9	14.8	4.2	15.9	4.4	16.7	4.6	17.4	4.7	17.8
UHPX-025	UHPXI-025	0.025	0.64	2.4	9.1	3.0	11.4	3.6	13.6	4.1	15.5	4.4	16.7	4.6	17.4	4.8	18.2	5.0	18.9
UHPX-026	UHPXI-026	0.026	0.66	2.5	9.5	3.2	12.1	3.8	14.4	4.3	16.3	4.7	17.8	5.0	18.9	5.2	19.7	5.5	20.8
UHPX-027	UHPXI-027	0.027	0.69	2.7	10.2	3.4	12.9	4.1	15.5	4.6	17.4	4.9	18.5	5.2	19.7	5.4	20.4	5.7	21.6
UHPX-028	UHPXI-028	0.028	0.71	2.8	10.6	3.6	13.6	4.3	16.3	4.9	18.5	5.2	19.7	5.5	20.8	5.7	21.6	6.0	22.7
UHPX-029	UHPXI-029	0.029	0.74	3.0	11.4	3.8	14.4	4.5	17.0	5.1	19.3	5.5	20.8	5.8	22.0	6.1	23.1	6.3	23.8
UHPX-030	UHPXI-030	0.030	0.76	3.2	12.1	4.0	15.1	4.7	17.8	5.4	20.4	5.8	22.0	6.1	23.1	6.4	24.2	6.7	25.4
UHPX-031	UHPXI-031	0.031	0.79	3.3	12.5	4.2	15.9	5.0	18.9	5.6	21.2	6.1	23.1	6.4	24.2	6.7	25.4	7.1	26.9
UHPX-032	UHPXI-032	0.032	0.81	3.5	13.2	4.4	16.7	5.2	19.7	5.9	22.3	6.4	24.2	6.8	25.7	7.2	27.3	7.5	28.4
UHPX-033	UHPXI-033	0.033	0.84	3.7	14.0	4.7	17.8	5.5	20.8	6.2	23.5	6.7	25.4	7.1	26.9	7.5	28.4	7.8	29.5
UHPX-034	UHPXI-034	0.034	0.86	3.9	14.8	4.9	18.5	5.8	22.0	6.5	24.6	7.0	26.5	7.4	28.0	7.8	29.5	8.2	31.0
UHPX-037	UHPXI-037	0.037	0.94	4.5	17.0	5.6	21.2	6.6	25.0	7.5	28.4	8.1	30.7	8.6	32.6	9.1	34.4	9.5	36.0
UHPX-038	UHPXI-038	0.038	0.97	4.7	17.8	5.9	22.3	6.9	26.1	7.8	29.5	8.4	31.8	9.0	34.1	9.5	36.0	10.0	37.9
UHPX-042	UHPXI-042	0.042	1.07	5.6	21.2	7.0	26.5	8.2	31.0	9.2	34.8	10.0	37.9	10.7	40.5	11.3	42.8	11.9	45.0
UHPX-046	UHPXI-046	0.046	1.17	6.6	25.0	8.2	31.0	9.6	36.3	10.8	40.9	11.7	44.3	12.5	47.3	13.3	50.3	14.0	53.0

Thrust numbers are marginal for rotation speed and may not clean well in difficult applications. Thrust < 25 lb-F

Manual Blasting 25 lb-F < Thrust < 67 lb-F

Light Duty Automated Blasting 67 lb-F < Thrust < 150 lb-F

Heavy Duty Automated Blasting Thrust > 150 lb-F

NOTE:

Preferred thrust for manual blasting is 1/3 the body weight of the operator. This chart assumes 200 lb. operator (67 lb-F thrust limit).

Thrust numbers exceeding 150 lbs.ft. may reduce performance of Orbi-Jet X22.

Flow rate values include lead-by GPM.



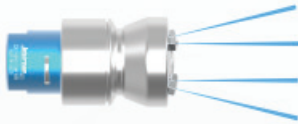

FOUR UHPX/UHPXI NOZZLES

UHPX NOZZLE PART NO.	UHPXI NOZZLE PART NO.	ORIFICE DIAMETER		5,000 psi (345 bar)		7,500 psi (517 bar)		10,000 psi (690 bar)		12,500 psi (862 bar)		15,000 psi (1,034 bar)		17,500 psi (1,207 bar)		20,000 psi (1,379 bar)		22,500 psi (1,551 bar)	
		in	mm	gpm	lpm	gpm	lpm	gpm	lpm	gpm	lpm	gpm	lpm	gpm	lpm	gpm	lpm	gpm	lpm
UHPX-018	UHPXI-018	0.018	0.46	2.5	9.5	3.1	11.7	3.7	14.0	4.2	15.9	4.5	17.0	4.8	18.2	5.0	18.9	5.2	19.7
UHPX-019	UHPXI-019	0.019	0.48	2.7	10.2	3.4	12.9	4.0	15.1	4.6	17.4	4.9	18.5	5.2	19.7	5.4	20.4	5.6	21.2
UHPX-020	UHPXI-020	0.020	0.51	2.9	11.0	3.7	14.0	4.3	16.3	4.9	18.5	5.3	20.1	5.6	21.2	5.8	22.0	6.1	23.1
UHPX-021	UHPXI-021	0.021	0.53	3.1	11.7	3.9	14.8	4.6	17.4	5.3	20.1	5.7	21.6	6.0	22.7	6.3	23.8	6.6	25.0
UHPX-022	UHPXI-022	0.022	0.56	3.4	12.9	4.2	15.9	4.9	18.5	5.7	21.6	6.1	23.1	6.5	24.6	6.8	25.7	7.1	26.9
UHPX-023	UHPXI-023	0.023	0.58	3.6	13.6	4.5	17.0	5.3	20.1	6.1	23.1	6.5	24.6	6.9	26.1	7.3	27.6	7.6	28.8
UHPX-024	UHPXI-024	0.024	0.61	3.9	14.8	4.9	18.5	5.7	21.6	6.5	24.6	7.0	26.5	7.4	28.0	7.8	29.5	8.2	31.0
UHPX-025	UHPXI-025	0.025	0.64	4.2	15.9	5.2	19.7	6.1	23.1	6.9	26.1	7.5	28.4	7.9	29.9	8.4	31.8	8.8	33.3
UHPX-026	UHPXI-026	0.026	0.66	4.4	16.7	5.5	20.8	6.5	24.6	7.3	27.6	8.0	30.3	8.6	32.6	9.0	34.1	9.5	36.0
UHPX-027	UHPXI-027	0.027	0.69	4.7	17.8	5.9	22.3	7.0	26.5	7.9	29.9	8.5	32.2	9.0	34.1	9.6	36.3	10.0	37.9
UHPX-028	UHPXI-028	0.028	0.71	5.1	19.3	6.3	23.8	7.4	28.0	8.4	31.8	9.0	34.1	9.6	36.3	10.2	38.6	10.7	40.5
UHPX-029	UHPXI-029	0.029	0.74	5.4	20.4	6.7	25.4	7.9	29.9	8.9	33.7	9.6	36.3	10.2	38.6	10.8	40.9	11.4	43.1
UHPX-030	UHPXI-030	0.030	0.76	5.7	21.6	7.1	26.9	8.3	31.4	9.4	35.6	10.2	38.6	10.9	41.3	11.5	43.5	12.1	45.8
UHPX-031	UHPXI-031	0.031	0.79	6.1	23.1	7.5	28.4	8.8	33.3	9.9	37.5	10.8	40.9	11.5	43.5	12.2	46.2	12.8	48.4
UHPX-032	UHPXI-032	0.032	0.81	6.4	24.2	7.9	29.9	9.3	35.2	10.5	39.7	11.4	43.1	12.2	46.2	13.0	49.2	13.7	51.9
UHPX-033	UHPXI-033	0.033	0.84	6.8	25.7	8.4	31.8	9.8	37.1	11.1	42.0	12.0	45.4	12.9	48.8	13.6	51.5	14.4	54.5
UHPX-034	UHPXI-034	0.034	0.86	7.2	27.3	8.9	33.7	10.4	39.4	11.7	44.3	12.7	48.1	13.6	51.5	14.4	54.5	15.2	57.5
UHPX-037	UHPXI-037	0.037	0.94	8.4	31.8	10.4	39.4	12.1	45.8	13.6	51.5	14.8	56.0	15.8	59.8	16.8	63.6	17.7	67.0
UHPX-038	UHPXI-038	0.038	0.97	8.8	33.3	10.9	41.3	12.7	48.1	14.3	54.1	15.5	58.7	16.6	62.8	17.6	66.6	18.6	70.4
UHPX-042	UHPXI-042	0.042	1.07	10.6	40.1	13.1	49.6	15.2	57.5	17.1	64.7	18.6	70.4	20.0	75.7	21.3	80.6	22.5	85.2
UHPX-046	UHPXI-046	0.046	1.17	12.6	47.7	15.5	58.7	18.1	68.5	20.3	76.8	22.1	83.6	23.7	89.7	25.2	95.4	26.7	101.1

Thrust numbers are marginal for rotation speed and may not clean well in difficult applications. Thrust < 25 lb-F

Manual Blasting 25 lb-F < Thrust < 67 lb-F

Light Duty Automated Blasting 67 lb-F < Thrust < 150 lb-F

Heavy Duty Automated Blasting Thrust > 150 lb-F

NOTE:

Preferred thrust for manual blasting is 1/3 the body weight of the operator. This chart assumes 200 lb. operator (67 lb-F thrust limit).

Thrust numbers exceeding 150 lbs. ft. may reduce performance of Orbi-Jet X22.

Flow rate values include lead-by GPM.

Warranty

Limited Warranty. Each Waterblast Unit, Bareshaft Pump, and Fluid End manufactured by Jetstream is warranted against defects in material and workmanship for a period of 12 months or 1,000 hours, provided it is used in a normal and reasonable manner and in accordance with all operating instructions. If sold to an end user, the applicable warranty period commences from the date of delivery to the end user. If used for rental purposes, the applicable warranty period commences from the date of delivery to the party holding the equipment available for rent. This limited warranty may be enforced by any subsequent transferee during the warranty period. This limited warranty is the sole and exclusive warranty given by Jetstream.

Exclusive Remedy. Should any warranted product fail during the warranty period, Jetstream will cause to be repaired or replaced, as Jetstream may elect, any part or parts of such Waterblast Unit, Bareshaft Pump, or Fluid End that the examination discloses in Jetstream's sole judgment to be defective in material or factory workmanship. Repairs or replacements are to be made at Jetstream in Houston, Jetstream FS Solutions Rental Center, the customer's location, or at other locations approved by Jetstream. Labor is furnished only when the unit or part is returned to the factory or when travel and expenses are paid by the purchaser. Freight, travel and expenses incurred in connection with repair or warranty are excluded from this warranty and shall be paid by the purchaser. The foregoing remedies shall be the sole and exclusive remedies of any party making a valid warranty claim.

The Jetstream Limited Warranty shall NOT apply to (and Jetstream shall NOT be responsible for):

1. Major components or trade accessories that have a separate warranty from their original manufacturer, such as, but not limited to: diesel engines, electric motors, electronic soft starter and/or across the line starter panels, axles, PTO's, clutch packs, high pressure gauges, high pressure hoses, flex lances, etc.
2. Normal adjustments and maintenance services.
3. Normal wear parts such as, but not limited to: oil, clutches, belts, filters, packing, cartridges, univalves, face seals, diffusers, gland nut bushings, plungers, nozzles, rupture disks, etc.

4. Failures resulting from the machine being operated in a manner or for a purpose not recommended by Jetstream including failures or malfunctions resulting from corrosion, misapplication, overpressurization, inadequate pump suction conditions, improper water quality, improper maintenance, or misuse.

5. Repairs, modifications or alterations which in Jetstream's sole judgment, have adversely affected the machine's stability, operation or reliability as originally designed and manufactured.

6. Items subject to misuse, negligence, accident or improper maintenance.

NOTE The use of any part other than ones approved by Jetstream may invalidate this warranty. Jetstream reserves the right to determine, in its sole discretion, if the use of non-approved parts invalidates the warranty. Nothing contained in this warranty shall make Jetstream liable for loss, injury, or damage of any kind to any person or entity resulting from any defect or failure in the machine or part.

THIS WARRANTY IS, AND SHALL BE IN LIEU OF ALL OTHER WARRANTIES, EXPRESS OR IMPLIED, INCLUDING WITHOUT LIMITATION, ANY IMPLIED WARRANTIES OF MERCHANTABILITY OR FITNESS FOR A PARTICULAR PURPOSE, ALL OF WHICH ARE DISCLAIMED. THIS DISCLAIMER AND EXCLUSION SHALL APPLY EVEN IF ANY WARRANTY POSSIBLY ASSERTED FAILS OF ITS ESSENTIAL PURPOSE.

This warranty is in lieu of all other obligations or liabilities, contractual and otherwise, on the part of Jetstream. For the avoidance of doubt, Jetstream shall not be liable for any indirect, special, incidental or consequential damages, including, but not limited to, loss of use or lost profits. Jetstream makes no representation that the unit has the capacity to perform any functions other than as contained in Jetstream's written literature, catalogs or specifications accompanying delivery of the machine. No person or affiliated company representative is authorized to alter the terms of this warranty, to give any other warranties or to assume any other liability on behalf of Jetstream in connection with the sale, servicing or repair of any machine manufactured by Jetstream. Any legal action based hereon must be commenced within eighteen (18) months of the event or facts giving rise to such action.

Jetstream reserves the right to make design changes or improvements in its products without imposing any obligation upon itself to change or improve previously manufactured products.

This page intentionally left blank.

This page intentionally left blank.

If questions exist, call your Jetstream representative at 1-800-231-8192 or visit www.waterblast.com.

Jetstream of Houston, LLP

5905 Thomas Rd.
Houston, TX 77041

www.waterblast.com



Application Policy

Capacity ratings, features, and specifications vary depending upon the model and type of service. Application approvals must be obtained from Jetstream; contact your representative for application approval. We reserve the right to change or modify our product specifications, configurations, or dimensions at any time without notice.